

Development of the methods of calculation of the electrical installations working operation in case of quality supply disturbance

Ismael Kareem Saeed¹

Kamal Sheikh Younis¹

¹Salahaddin University – Erbil – College of Engineering, Electrical Engineering Department

Article Inform

Article History:

Received 24 April 2020

Accepted 27 Aug 2020

Available online 30 December 2020

Keywords: Power systems, symmetrical components, asymmetry of supply, mathematical models.

About the Authors:

Corresponding author:

Kamal Sheikh Ypunis

E-mail: kamal.sheikhyounis@su.edu.krd

Researcher Involved:

Ismael Kareem Saeed

DOI Link: <https://doi.org/10.17656/sjes.10138>



© The Authors, published by University of Sulaimani, college of engineering. This is an open access article distributed under the terms of a Creative Commons Attribution 4.0 International License.

Abstract

This paper proposes a method of calculating of asymmetrical modes of operation of electrical installations where simple and adequate loads equivalent circuits are available with working electrical equipment.

So the mathematical model of equation system is derived as universal way for calculating the systems operating modes when it is subjected to a disturbance due to asymmetry.

With the help of the obtained model, we can calculate different cases of symmetry disturbances, all types of short circuits, between phase short circuits, any type of longitudinal asymmetry, open circuits when there is a resistance for the fault current at the place of damage.

In the given method, specific types of asymmetry are considered as particular cases and easily calculated from the generalized formula, which is essentially reduces the calculation and allows us to consider cases of asymmetry of any complexity. Therefore, this method is offered as a basic for calculation of asymmetry when the system is subjected to a disturbance.

1. Introduction

As we know the electrical loads of many enterprises, residential and public buildings carry a non-uniformly character, that is, the single-phase loads are unevenly distributed by phases or the loads of three-phase receivers are asymmetrical in phases, which have a significant impact on the quality of the supply. In electrical

networks the asymmetry occurs as a result of various failures or the switching's (different short-circuits, open circuits incomplete phase breaks). Below is a method of calculating of asymmetrical modes of operation of electrical installations where simple and adequate loads equivalent circuits are available with working electrical equipments (Göran, 2012).

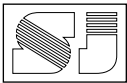

Real electrical supply systems to varying degrees are non-linear, at least due to non-linearity type of magnetic saturation of generators and transformers. However, if we limit ourselves to considering the only main harmonic component of current and voltage in the power system and perform a piece-linear approximation of non-linearity, the condition of admissibility of the use of symmetrical components is fulfilled and can be used for investigation of asymmetrical modes of power system.

Adaptive equivalent technique applied as a putrefaction method for the subsystems and their subsequent equivalent (Krumm and Mantrov, 1993). Asymmetrical conditions of the power system sequence network got by the vector of operating parameters and control it with using a technique implies preliminary determination of the initial approximation (Voitov, Mantrov and Semenova, 1997; 1998, pp. 740-744). A short historical of the symmetrical-component transformation overviewed in the time domain and the application of unitary and orthogonal transformations (Gerardus, May 2000, pp. 522-528). The global voltage unbalance addressed in MV power systems arising as a result of line asymmetries (Paranavithana et al, 2009, pp. 2353-2360). The standard concerning electric power quality studied which produced by wind power plants (Jan and Boguslaw, 2009). The back/forward sweep method improved by adopting two incident matrices to characterize the topology (Liu et al, 2012). A circuit approach to the phenomenon of voltage unbalance emission due to line asymmetries provided in three-phase power systems (Diego and Sergio, 2015). The mathematical model used to study the main dependencies of the change in the values of the unbalance coefficients of the negative sequence voltage on the power of the power transformer at different power values of a three-phase AC voltage source (Konstantin et al, 2017). Neural networks presented and compared with methods: Fourier transform, wavelet transforms, Hilbert-Huang transforms, S-transforms as algorithms for detection and classification of voltage distortion types (Alexandra et al, 2017, pp. 485-490). Reduced the harmonics as

well as improving the overall power quality of the system (Sufyanu, 2018). Control strategy improved with relatively simple implementation, aimed at the mitigation of negative sequence currents (Boris et al, 2019). A new equivalent circuit of compensated distributed networks CDNs proposed which accounts for the asymmetry in the power line networks based on a comprehensive mathematical analysis (Ameen, Amanullah and Martin, 2019). The instantaneous symmetrical component method proposed based on adaptive notch filter (Jian et al, 2019, pp. 4231-4237).

This paper proposes the mathematical model of asymmetrical component equation system for calculating the systems in different cases of symmetry disturbances.

2. Methodology and equations for calculating asymmetrical modes of power supply system

Varieties of asymmetrical modes arising as a result of breakdown conditions were considered in literature but, the most common case of longitudinal asymmetry has not been examined. This is the one case where there are no failure but the impedance of phases are different that is the phases are unevenly loaded which is why the symmetry of the 3-phase system is broken. Therefore it is necessary to consider the general case of single longitudinal asymmetry to analyze the work of electrical network and analyze the indexes of quality of power supply and on the basis of the general we can consider any individual case including an emergency case. Having a mathematical model for a common case, we can solve any practical problem related to the symmetry disruption longitudinal and transverse asymmetry.

2.1 General case of single longitudinal and transverse asymmetry

For calculating a general case of single asymmetry, consider asymmetrical network section of figure 1.

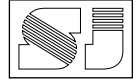

It is known that, asymmetrical 3-phase system of vectors can be replaced by the combination of three symmetrical systems of positive, negative and zero sequence components which we will represent as follows (Fortescue, 1918, pp-1027-1140; Chemin and Losev, 1983):

$$\left. \begin{aligned} A &= A_1 + A_2 + A_0; \\ B &= a^2 \cdot A_1 + a \cdot A_2 + A_0; \\ C &= a \cdot A_1 + a^2 \cdot A_2 + A_0; \end{aligned} \right\} \quad (1)$$

Where A,B,C – 3-phase asymmetrical system of vectors; A_1, A_2, A_0 – symmetrical components of positive, negative and zero sequence components.

$$a = e^{j\frac{2\pi}{3}} = -\frac{1}{2} + j\frac{\sqrt{3}}{2}; \quad a^2 = e^{j\frac{4\pi}{3}} = -\frac{1}{2} - j\frac{\sqrt{3}}{2}$$

Phase multiplier (Das, 2017)

A common case of transverse asymmetry can be presented schematically in the following form (figure 2.)

Where k^n – is a form of transverse asymmetry; $\Delta\dot{U}_A; \Delta\dot{U}_B; \Delta\dot{U}_C$ – voltage drop in phases at the point of damage (asymmetry); $\Delta\dot{U}_{1k}; \Delta\dot{U}_{2k}; \Delta\dot{U}_{0k}$ – symmetrical components of the voltage drops.

For application of the method of symmetrical component in complex power systems we apply equivalent circuit components (Figure 3.) for which we obtain the following system of equations:

$$\left. \begin{aligned} \Delta U_{1k} &= E_{1k} - I_{1k}Z_1; \\ \Delta U_{2k} &= -I_{2k}Z_2; \\ \Delta U_{0k} &= -I_{0k}Z_0. \end{aligned} \right\} \quad (2)$$

$$\left. \begin{aligned} \Delta U_A &= I_A Z_A; \\ \Delta U_B &= I_B Z_B; \\ \Delta U_C &= I_C Z_C, \end{aligned} \right\} \quad (3)$$

Where E_{k1} – total positive sequence (e.m.f)s when transverse asymmetry; I_A, I_B, I_C – total currents in phases A, B, C in phase coordinates; I_{1k}, I_{2k}, I_{0k} – symmetrical components of currents of positive, negative and zero sequences at the point of damage in transverse asymmetry;

Z_A, Z_B, Z_C – total impedances of phases A,B and C relative to the point of damage in phase coordinates; Z_1, Z_2, Z_0 – networks impedance in symmetrical coordinates; $\Delta U_A, \Delta U_B, \Delta U_C$ – voltage drop in phases in the point of damage (asymmetry).

The general case of longitudinal asymmetry is schematically presented in the (figure.4) where $L^{(n)}$ – a type of longitudinal asymmetry; $\Delta U_{1L}, \Delta U_{2L}, \Delta U_{0L}$ – symmetrical components of voltage drops. Using the method of superposition, we will compile the sequence replacement of equivalent circuits similar to given in figure 3. We obtain the following equations:

$$\left. \begin{aligned} \Delta U_{1L} &= E_{1L} - I_{1L}Z_1; \\ \Delta U_{2L} &= -I_{2L}Z_2; \\ \Delta U_{0L} &= -I_{0L}Z_0 \end{aligned} \right\} \quad (4)$$

Where, I_{1L}, I_{2L}, I_{0L} – the currents of positive, negative and zero sequence components in the point of an open circuit.

From a mathematical point of view it is not difficult to notice the similarity of formulas (2) and (4) which differs only by physical meaning i.e. the type of asymmetry. The mathematical model in the form of equations (2) and (4) allows investigate the general case of asymmetry using identical formulas to calculate both longitudinal and transverse asymmetry, however, with reservation of the type of asymmetry.

Let us write down the equations (2) and (4) in the following form:

$$\left. \begin{aligned} \Delta U_1 &= E_1 - I_1 Z_1; \\ \Delta U_2 &= -I_2 Z_2; \\ \Delta U_0 &= -I_0 Z_0 \end{aligned} \right\} \quad (5)$$

Decomposing, in the system of equations (3), the current and voltage vectors to symmetrical components and substituting expressions in the system equation (3) from the system (5) we get the following equations:

$$\left. \begin{aligned} I_1(Z_A + Z_1) + I_2(Z_A + Z_2) + I_0(Z_A + Z_0) &= E_1; \\ a^2 I_1(Z_B + Z_1) + a I_2(Z_B + Z_2) + I_0(Z_B + Z_0) &= a^2 \cdot E_1; \\ a I_1(Z_C + Z_1) + a^2 I_2(Z_C + Z_2) + I_0(Z_C + Z_0) &= a \cdot E_1 \end{aligned} \right\} \quad (6)$$

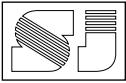

By solving the equation system (6), we will find the expressions for sequence currents, expressed through phase-impedance and sequences and the total (e.m.f) s of positive sequence:

$$I_1 = \frac{3Z_2Z_0 + (Z_2 + Z_0)(Z_A + Z_B + Z_C) + Z_A Z_B + Z_B Z_C + Z_A Z_C}{3Z_A Z_B Z_C + 3Z_1 Z_2 Z_0 + (Z_1 + Z_2 + Z_0)(Z_A Z_B + Z_B Z_C + Z_A Z_C) + (Z_A + Z_B + Z_C)(Z_1 Z_2 + Z_2 Z_0 + Z_1 Z_0)} \cdot E_1 \tag{7}$$

$$I_2 = \frac{a^2 Z_A Z_B + Z_B Z_C + a Z_A Z_C - Z_0(Z_A + a Z_B + a^2 Z_C)}{3Z_A Z_B Z_C + 3Z_1 Z_2 Z_0 + (Z_1 + Z_2 + Z_0)(Z_A Z_B + Z_B Z_C + Z_A Z_C) + (Z_A + Z_B + Z_C)(Z_1 Z_2 + Z_2 Z_0 + Z_1 Z_0)} E_1 \tag{8}$$

$$I_0 = \frac{a Z_A Z_B + Z_B Z_C + a^2 Z_A Z_C - Z_2(Z_A + a^2 Z_B + a Z_C)}{3Z_A Z_B Z_C + 3Z_1 Z_2 Z_0 + (Z_1 + Z_2 + Z_0)(Z_A Z_B + Z_B Z_C + Z_A Z_C) + (Z_A + Z_B + Z_C)(Z_1 Z_2 + Z_2 Z_0 + Z_1 Z_0)} \cdot E_1 \tag{9}$$

Using the method of symmetrical components and expressions, total phase currents can be obtained. Therefore, we can find the currents in the phases in general, when phase impedances are not equal. Now let us represent the rule of the equivalency of the positive sequence in general form. Analyzing expressions (7, 8, 9) and equation system (4) and (5), we arrive to the conclusion that, negative and zero sequence currents and voltages of all sequences are proportional to the positive sequence current. Therefore the problem of calculating of any asymmetrical condition, first of all is to find the current of positive sequence in the point of supposed asymmetry. Although the positive sequence equivalency rule was formulated earlier in the literature but no one has derived a general formula and only particular cases were considered.

After conducting some manipulation the expression (4) can be represented as follows:

$$\dot{I}_1 = \frac{E_1}{Z_1 + \Delta Z_1}; \tag{10}$$

$$\Delta Z_1 = \frac{3Z_A Z_B Z_C + (Z_2 + Z_0)(Z_A Z_B + Z_B Z_C + Z_A Z_C) + Z_2 Z_0(Z_A + Z_B + Z_C)}{(Z_A Z_B + Z_B Z_C + Z_A Z_C) + (Z_2 + Z_0)(Z_A + Z_B + Z_C) + 3Z_2 Z_0}; \tag{11}$$

Where ΔZ_1 – additional impedance.

Introducing the designation:

$$K_{ABC} = Z_A Z_B + Z_B Z_C + Z_A Z_C \text{ and } K_{\Sigma} = Z_A + Z_B + Z_C$$

the

expression (11) can be written as:

$$\Delta Z_1 = \frac{3Z_A Z_B Z_C + K_{ABC}(Z_2 + Z_0) + K_{\Sigma}(Z_2 Z_0)}{K_{ABC} + K_{\Sigma}(Z_2 + Z_0) + 3Z_2 Z_0}. \tag{12}$$

Thus, a generalized rule of positive sequence component equivalency has been obtained.

In the same way we can obtain ΔZ_2 and ΔZ_0 .

$$\Delta Z_2 = \frac{3Z_A Z_B Z_C + 3Z_1 Z_2 Z_0 + K_{ABC}(Z_1 + Z_2 + Z_0) + K_{\Sigma}(Z_1 Z_2 + Z_1 Z_0 + Z_2 Z_0) - a^2 Z_2 Z_A Z_B - Z_2 Z_B Z_C - a Z_2 Z_A Z_C + Z_2 Z_0(Z_A + a^2 Z_B + a^2 Z_C)}{a^2 Z_A Z_B + Z_B Z_C + a Z_A Z_C - Z_0(Z_A + a Z_B + a^2 Z_C)} \tag{13}$$

And

$$\Delta Z_0 = \frac{3Z_A Z_B Z_C + 3Z_1 Z_2 Z_0 + K_{ABC}(Z_1 + Z_2 + Z_0) + K_{\Sigma}(Z_1 Z_2 + Z_1 Z_0 + Z_2 Z_0) - a Z_A Z_B Z_0 - Z_B Z_C Z_0 - a^2 Z_A Z_C Z_0 + Z_2 Z_0(Z_A + a^2 Z_B + a Z_C)}{a Z_A Z_B + Z_B Z_C + a^2 Z_A Z_C - Z_2(Z_A + a^2 Z_B + a Z_C)} \tag{14}$$

$$\dot{I}_2 = \frac{E_1}{Z_2 + \Delta Z_2}; \tag{15}$$

$$\dot{I}_0 = \frac{E_1}{Z_0 + \Delta Z_0}; \tag{16}$$

2.2 Single- phase open-circuit

In electrical networks, among all kinds of longitudinal asymmetry, the occurrence of one phase open- circuit as shown in Figure 5, encountered more often and regarded as a very common case, so for confirming the correctness of formulas (7,8,9) we consider just this case.

For a given schema of Figure 5, we have: $Z_B = Z_C = 0, Z_A = \infty$. Substituting those values

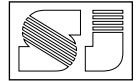

in the formulas (7), (8), and (9) we obtain the expression for calculating the case of single longitudinal asymmetry:

$$I_{1L} = \frac{Z_2 + Z_0}{Z_1 Z_2 + Z_2 Z_0 + Z_1 Z_0} \dot{E}_1; \quad (13)$$

$$I_{2L} = \frac{-Z_2}{Z_1 Z_2 + Z_2 Z_0 + Z_1 Z_0} \dot{E}_1; \quad (14)$$

$$I_{0L} = \frac{-Z_0}{Z_1 Z_2 + Z_2 Z_0 + Z_1 Z_0} \dot{E}_1; \quad (15)$$

$$\dot{I}_A = \dot{I}_{1L} + \dot{I}_{2L} + \dot{I}_{0L} = 0, \quad (16)$$

Where $\dot{I}_{1L}, \dot{I}_{2L}, \dot{I}_{0L}$ – The currents of positive, negative and zero sequence components in the place of open-circuit.

2.3 Single-phase short circuit

Now let's consider the case of transverse asymmetry. In failures, short-circuits, the short between phases most common of cases is a single-phase short circuits (70% of cases). For this schema (figure 6) we have:

$$Z_A = 0, Z_B = Z_C = \infty;$$

Substituting these values in the formulas (7), (8), (9) we get the following expressions:

$$\dot{I}_{1k} = \frac{\dot{E}_1}{Z_1 + Z_2 + Z_0}; \quad (17)$$

$$\dot{I}_{2k} = \frac{\dot{E}_1}{Z_1 + Z_2 + Z_0}; \quad (18)$$

$$\dot{I}_{0k} = \frac{\dot{E}_1}{Z_1 + Z_2 + Z_0}; \quad (19)$$

$$\dot{I}_A = \frac{3\dot{E}_1}{Z_1 + Z_2 + Z_0}; \quad (20)$$

$$\dot{I}_B = \dot{I}_C = 0; \quad (21)$$

Where $\dot{I}_{1k}, \dot{I}_{2k}, \dot{I}_{0k}$ – The currents of positive, negative and zero sequence components in the place of the short circuit..

Hence, with the help of the generalized formulas (7), (8), (9) it is possible to consider any particular case of both longitudinal and transverse asymmetry and getting absolutely specific and necessary in practice results. So the mathematical model in the form of equations (7), (8), (9) is a universal way for calculating the systems operating modes when it is subjected to a disturbance due to asymmetry.

With the help of the obtained model we can calculate different cases of symmetry disturbances: all types of short circuits, between phase short circuits (even taking into account the arc impedance), any type of longitudinal asymmetry, open circuits when there is resistance in the place of damage.

3. Simulation Case Study and Results

Commonly the calculation of single phase to ground fault current done by applying equation (20), other types of faults done by other commonly use functions, all results are approximate values. However, the actual results can be done by applying specified developments functions (10), (15) and (16) upon all types of faults.

IEEE 13-bus distribution power system is one of the general systems to take for the proposed work, with a view to predestine and compare the results with those of the specified developments function, an IEEE 13-bus distribution network has been selected as a sample. It should be realize that the specified developments equation can be generalized to be used for all distribution networks with any number of buses. The basic data for the test feeder can be found on the website

(<http://ewh.ieee.org/soc/pes/dsacom/testfeeders/index.html>). Table 1 shows the impedance data of the lines (Chiang and Wang, 1995, p. 363-369; Kersting and Shirek, 2012).

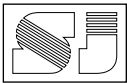

The equivalent sequence impedances are not included in that data of the equivalent system. Figure 7 shows the case study of the proposed simulation network.

The positive, negative and zero sequence impedances of the equivalent system are:

$$Z_{012} = \begin{cases} 0.3474 + j8.518 \Omega \\ 0.7673 + j4.7852 \Omega \\ 0.7673 + j4.7852 \Omega \end{cases}$$

and the phase impedance matrix in ohms is

$$Z_{ABC} = \begin{bmatrix} 0.6273 + j6.0295 & -0.14 + j1.2443 & -0.14 + j1.2443 \\ -0.14 + j1.2443 & 0.6273 + j6.0295 & -0.14 + j1.2443 \\ -0.14 + j1.2443 & -0.14 + j1.2443 & 0.6273 + j6.0295 \end{bmatrix}$$

Network data are:

- Source Voltage 4160V, resistance 0.8929 Ω and inductance 0.01658 H.
- Fault impedance is 0.001 Ω and ground impedance is 0.01 Ω .
- Shunt capacitor banks neglected.

Showing analysis and simulate figures results of Node 634 as a template for the entire system results by using Matlab R2019b.

Table 2 shows the sample results from general calculation and Specified proposed calculation for the three-phase short circuit and single-phase to ground short circuit of the system case study. Table 3 shows the one line open circuit from general calculation and Specified proposed calculation of the system case study. The specified proposal equations can apply on the all types of disturbances and test it.

Figures 8 and 9 show the three-phase voltages and currents respectively pre of faults at bus 634. Figures 10 to 15 show the responses of voltages and currents when a three-phase to ground short circuit, single line A to ground short circuit and one line A open circuit occurs at the same bus.

4. Conclusion

The approach of paper viewing that calculating of the asymmetry is changing, whereas in the past, specific cases of asymmetry have been solved with

the help of initial system of equations and consequences from boundary conditions, which the calculation rather cumbersome and it was convenient only for the simplest cases when this required a separate calculation for each case.

In the given method, specific types of asymmetry are considered as particular cases and easily calculated from generalized formula, which is essentially reduces the calculation and allows us to consider cases of asymmetry of any complexity. A method for analyzing short circuit currents for radial distribution feeders was outlined. The short circuit currents for the IEEE 13 Node Test Feeder were computed using special calculation method driving from symmetrical network equations instead of general form calculation.

To calculate the asymmetry, we just need to know the type of the asymmetry, and with a ready-made generalized formulas, we can calculate any particular case, that's the universality of formulas and generalized approach to calculate the asymmetry. Therefore this method is offered as a basic for calculation of asymmetry when the system is subjected to a disturbance.

References

1. Alexandra Chupakhina, Miroslav Martinovich, Gennady Zinoviev and Vladimir Skolota, 2017. "Modern Mathematical Methods and Computerized Tools of Artificial Intelligence for Solving Problems of Identifying the Energy Quality of Electrical Systems", *IEEE, SIBIRCON*.
2. Ameen Gargoom, Amanullah M.T. Oo, and Martin Cavanagh, 2019. "A Method for Calculating the Asymmetry in the Shunt Parameters of Power Lines in Compensated Distribution Networks", *IEEE, Transactions on Power Delivery*.
3. Boris Dumnic, Bane Popadic, Dragan Milicevic, Nikola Vukajlovic and Marko Delimar, 2019. "Control Strategy for a Grid Connected Converter in Active Unbalanced Distribution Systems", *Energies, 12, 1362*.
4. Chemin A.B., and S.B. Losev, 1983. "Calculation of electrical magnitudes and, asymmetrical conditions of electric networks", *Moskva: Energoatomizdat*.
5. Chiang H.D., and J. C. Wang, 1995. "Optimal Capacitor Placement Replacement and Control in Scale Unbalanced Systems", *IEEE Transactions on Power Apparatus and systems, Vol. 10, No. 1, pp. 363-369. doi:10.1109/59.373956*
6. Das J.C., (2017). "Understanding Symmetrical Components for Power System modeling" First Edition, IEEE, Published by John Wiley & Sons, Inc.

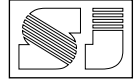

7. Diego Bellan and Sergio A. Pignari, 2015. "Circuit Representation of Voltage Unbalance Emission Due to Line Asymmetry", *IEEE Innovative Smart Grid Technologies, Asia*.
8. Fortescue C.L., Jun 28 1918. "Method of symmetrical coordinates applied to the solution of polyphase networks", *34th Annual conversion of the American Institute of Electrical Engineers*, 37:1027-1140.
9. Gerardus C. Paap, May 2000. "Symmetrical components in the time domain and their application to power network calculations", *IEEE Trans. Power System*, 15(2); 522-528,.
10. Göran Andersson, (Sep. 2012). "Power System Analysis", Lecture 227-0526-00, EEH - Power Systems Laboratory. ITET ETH Zurich. Swiss Federal Institute of Technology Zurich
11. Haoming Liu, Shun'an Cheng, Chunyan Huang, Yunhe Hou, 2012. "Unbalanced Power Flow Calculation for Lowvoltage Distribution Systems including DGs", *IEEE, PES ISGT, 1569536163, Asia*.
12. Jan A., Boguslaw T., Sep. 15-17, 2009. "Analysis of Electric Power Quality A Case Study: Kamiensk Wind Power Plant" *10th International conference, Electrical Power Quality*, Lodz, Poland.
13. Jian G, Xiaobo Y, Jiawen S, Pengfei Y, Roaidar K, 2019. "Modeling and Simulation of a Positive and Negative Sequence Component Separation for Grid Voltage Based on the Improved Method of Instantaneous Symmetrical Components", *The 31th Chinese Control and Decision Conference (CCDC)*.
14. Kersting W.H., and Greg Shirek, 2012. "Short Circuit Analysis of IEEE Test Feeders", *PES T&D, IEEE Conference, Orlando, FL, USA*. DOI: 10.1109/TDC.2012.6281539
15. Konstantin V. Khatsevskiy, Alexander I. Antonov, Tatjana V. Gonenko and Vladimir F. Khatsevskiy, Nov. 14-16, 2017. "The Voltage Asymmetry in Electrical Networks with Single-Phase Load", *IEEE Dynamics of Systems, Mechanisms and Machines (Dynamics)*, Omsk, Russia.
16. Krumm L.A., V.A. Mantrov, 1993. "Methods of adaptive equivalenting in problem of analysis of steady-state conditions of power systems" *Harwood Academic Publishers GmbH Printed in the USA*.
17. Paranavithana P., S. Perera, R. Koch and Z. Emin, Oct.2009. "Global Voltage Unbalance in MV Networks Due to Line Asymmetries," in *IEEE Transactions on Power Delivery*, vol. 24, no. 4, pp. 2353-2360.
18. Sufyanu A., 2018. "Power Quality and Harmonic Analysis in Three Phase Systems", *Journal of Electrical & Electronic Systems Vol. 7, Issue 4*.
19. Voitov O.N., Mantrov V.A., Semenova L.V., 1998. "Improvement of the analysis and control efficiency of power system asymmetrical conditions by equivalent transformation", *IEEE Q-7803-4754-4198*.
20. Voitov O.N., V. Mantrov, L.Semenova, Sep. 1997. "Analysis and control of open-phase conditions of electric over systems to improve power quality", *Proceedings of EPQU-97, 4th International Conference, Cracow, Poland*.

تطوير طرق حساب عمل التركيبات الكهربائية في حالة حدوث اضطراب في جودة الطاقة الكهربائية

أ.م.د. اسماعيل كريم سعيد¹

أ.م.د. كمال شيخ يونس¹

¹جامعة صلاح الدين/ أربيل، كلية الهندسة، قسم الهندسة الكهربائية

المستخلص

في هذا البحث، تم اقتراح طريقة لحساب الانماط غير المتكافئة لتشغيل التركيبات الكهربائية حيث تتوفر دوائر متكافئة بسيطة وكافية للأجهزة الكهربائية العاملة. لذا تم اشتقاق النموذج الرياضي لنظام المعادلة كطريقة عامة. لحساب اوضاع تشغيل الانظمة عندما تتعرض لاضطراب بسبب عدم التماثل. بمساعدة النموذج الذي تم اقتراحه يمكننا حساب حالات مختلفة من اضطرابات التناظر وجميع انواع الدوائر القصيرة، الدوائر القصيرة بين الاطوار، او اي نوع من التماثل الطولي، والدوائر المفتوحة عندما تكون هناك مقاومة في مكان الضرر. في الطريقة المقترحة تعتبر انواع معينة من عدم التماثل كحالات خاصة ويمكن حسابها بسهولة من المعادلة العامة، مما يقلل بشكل اساسي من الحسابات المعقدة ويسمح لنا بالنظر في جميع حالات عدم التماثل مهما كانت معقدة. لهذا السبب يتم تقديم هذه الطريقة كاساس لحساب حالات عدم التماثل عندما يتعرض النظام الكهربائي للاضطراب.

الكلمات المفتاحية: أنظمة القوى، المكونات المتناظرة، عدم تناسق الامدادات الكهربائية، النماذج الرياضية.

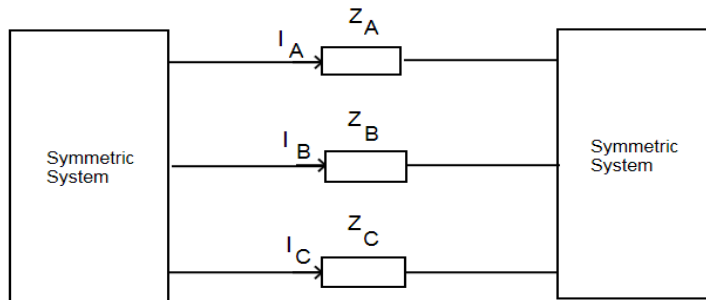
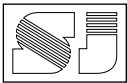

Fig. 1: Asymmetrical network section.

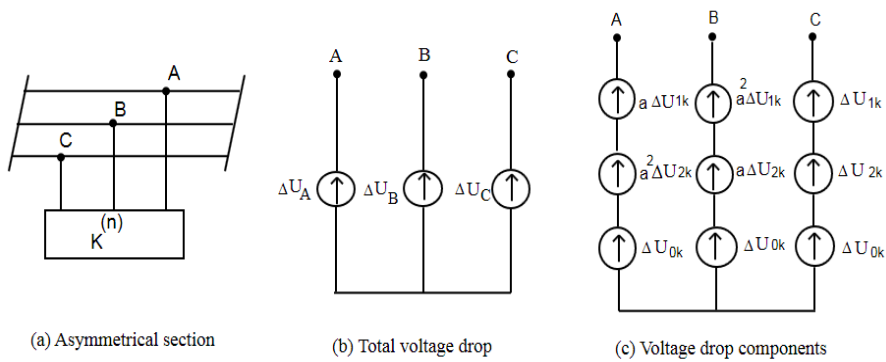

Fig. 2: General case of transverse asymmetry.

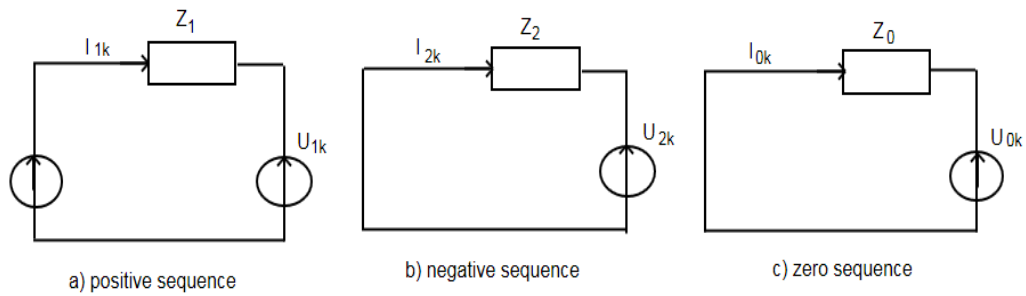

Fig. 3: Equivalent circuits of sequences.

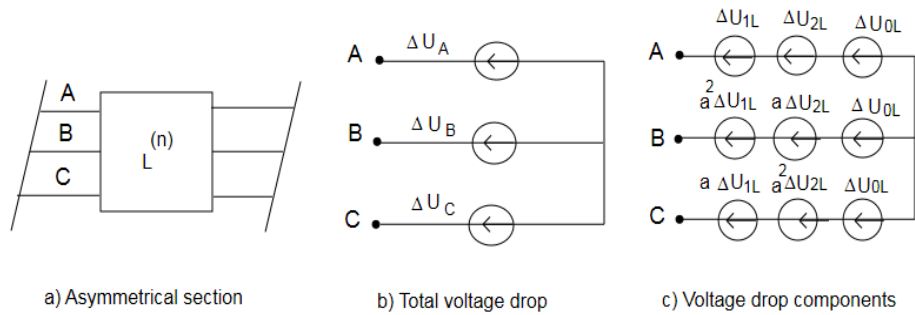
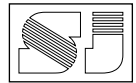

Fig. 4: General case of longitudinal asymmetry.

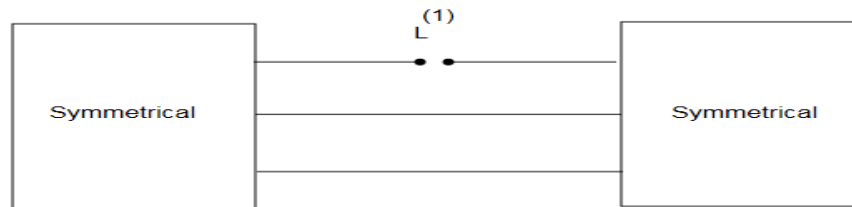

Fig. 5: One phase open-circuit.

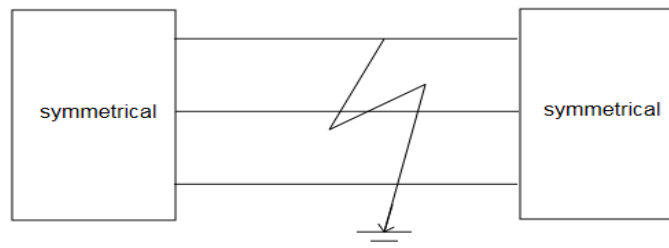

Fig. 6: Single phase short-circuit.

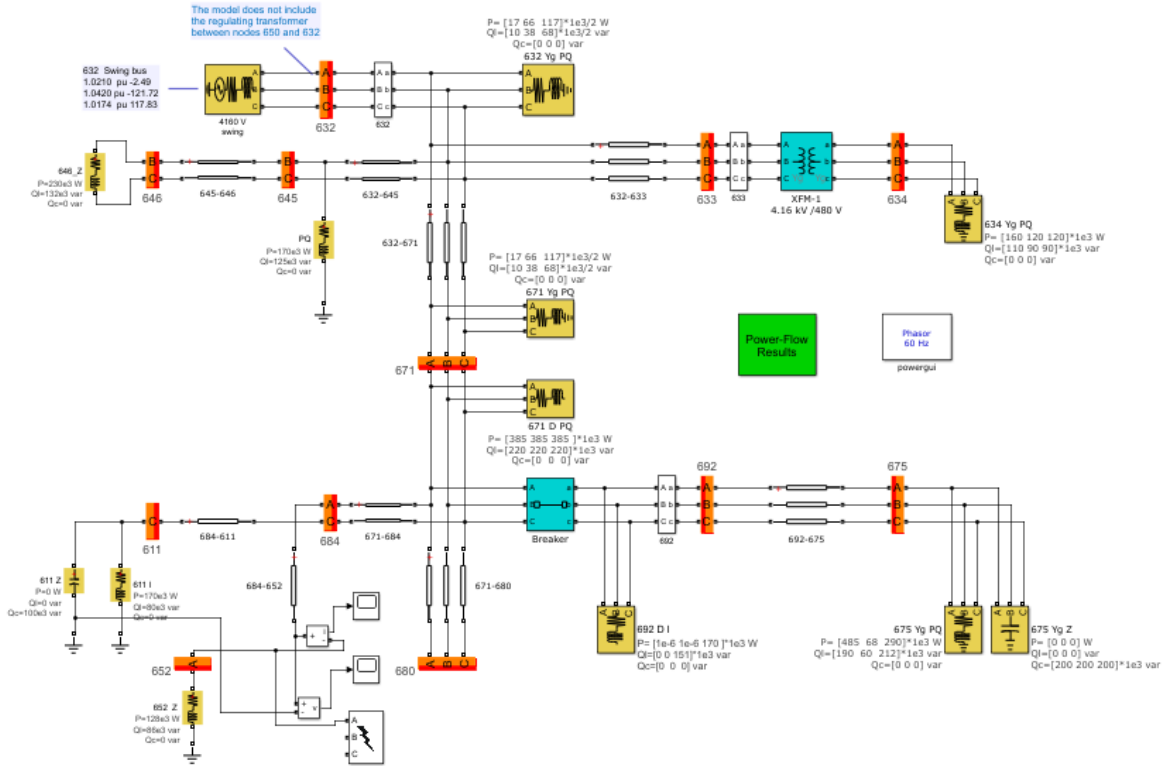
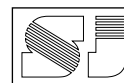

Fig. 7: IEEE 13-bus distribution power systems.

Table 1: Data of the lines system.

| Se. Bus | Re. Bus | R(Ω) | X(Ω) |
|---------|---------|---------------|---------------|
| 1 | 2 | 0.176 | 0.138 |
| 2 | 3 | 0.176 | 0.138 |
| 3 | 4 | 0.045 | 0.035 |
| 4 | 5 | 0.089 | 0.069 |
| 5 | 6 | 0.045 | 0.035 |
| 5 | 7 | 0.116 | 0.091 |
| 7 | 8 | 0.073 | 0.073 |
| 8 | 9 | 0.074 | 0.058 |
| 8 | 10 | 0.093 | 0.093 |
| 7 | 11 | 0.063 | 0.050 |
| 11 | 12 | 0.068 | 0.053 |
| 7 | 13 | 0.062 | 0.053 |

**Table 2: Short-Circuit Currents - IEEE 13 Node.**

| Bus | Phase | Three- Phase Fault rms value | | Single line to ground fault rms value | | | Single line to ground fault Phase rms value | | |
|-----|--------|------------------------------|-------------------------------|---------------------------------------|----|------------|---|----------|------------|
| | | General Calculation (Amps) | Spec. Pro. Calculation (Amps) | General Calculation (Amps) | | | Spec. Pro. Calculation (Amps) | | |
| | | | | IA | IB | IC | IA | IB | IC |
| 692 | ABC& A | 3.3502e+03 | 3.3502e+03 | 2196.3 | 0 | 0 | 2.3882e+03 | 414.42 | 416.8582 |
| 680 | ABC& A | 2.9098e+03 | 2.9098e+03 | 1.8519e+03 | 0 | 0 | 2.0531e+03 | 409.3545 | 412.165 |
| 675 | ABC& A | 3.1212e+03 | 3.1212e+03 | 2.0771e+03 | 0 | 0 | 2.2594e+03 | 408.5804 | 411.0386 |
| 671 | ABC& A | 3.3502e+03 | 3.3502e+03 | 2.1963e+03 | 0 | 0 | 2.3882e+03 | 414.4131 | 416.8513 |
| 633 | ABC& A | 4.1503e+03 | 4.1503e+03 | 2.9506e+03 | 0 | 0 | 3.1074e+03 | 414.8966 | 416.6461 |
| 632 | ABC& A | 4.8036e+03 | 4.8036e+03 | 3.4960e+03 | 0 | 0 | 3.6435e+03 | 417.7669 | 419.2572 |
| 684 | A | | | 2.0194e+03 | 0 | 0 | 2.1245e+03 | 0 | 407.3992 |
| 652 | A | | | 1.7957e+03 | 0 | 0 | 1.7957e+03 | 0 | 0 |
| 645 | B | | | 0 | 0 | 2.8065e+03 | 0 | 422.4444 | 2.8934e+03 |
| 646 | C | | | 0 | 0 | 2.5165e+03 | 0 | 415.0064 | 2.6198e+03 |
| 611 | C | | | 0 | 0 | 1.8520e+03 | 0 | 0 | 1.8541e+03 |
| 634 | ABC& A | 1.5260e+04 | 1.5260e+04 | 1.3047e+04 | 0 | 0 | 1.3056e+04 | 52.0162 | 52.7757 |

Table 3: Open-Circuit IEEE 13 Node.

| Bus | Phase | One Line Open Circuit | | | | | |
|-----|-------|--------------------------------------|----------|----------|---|-------|-------|
| | | General Calculation rms value (Amps) | | | Spec. Pro. Calculation rms value (Amps) | | |
| | | IA (A) | IB(A) | IC(A) | IA (A) | IB(A) | IC(A) |
| 692 | A | 0 | 162.2168 | 162.0830 | 0 | 96.68 | 177.3 |
| 680 | A | 0 | 0 | 0 | 0 | 0 | 0 |
| 675 | A | 0 | 168.9129 | 168.7870 | 0 | 96.65 | 177.4 |
| 671 | A | 0 | 447.2297 | 447.0775 | 0 | 276.5 | 418.6 |
| 633 | A | 0 | 117.3008 | 117.1250 | 0 | 86.61 | 89.26 |
| 632 | A | 0 | 560.6359 | 560.4454 | 0 | 572.5 | 735 |
| 684 | A | 0 | 0 | 150.5115 | 0 | 0 | 101.9 |
| 652 | A | 0 | 0 | 0 | 0 | 0 | 0 |
| 645 | B | 0 | 0 | 74.09575 | 0 | 0 | 0 |
| 646 | B | 0 | 0 | 70.8461 | 0 | 0 | 0 |
| 611 | C | 0 | 0 | 0 | 0 | 0 | 0 |
| 634 | A | 0 | 751.6034 | 751.5859 | | 748.2 | 771.2 |

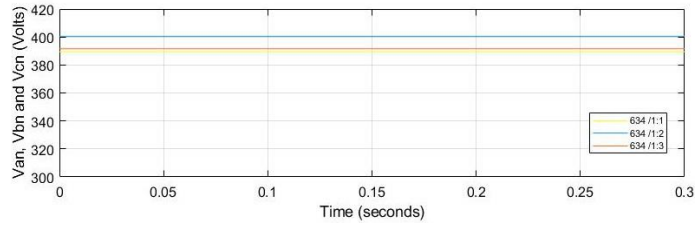
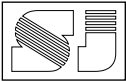

Fig. 8: Bus 634 three-phase to neutral voltages at steady-state.

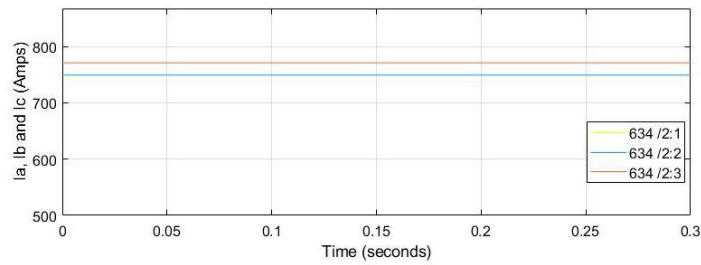

Fig. 9: Bus 634 three-phase currents at steady-state.

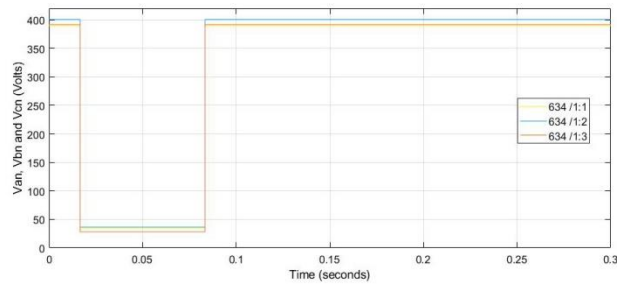

Fig. 10: Bus 634 three-phase to neutral voltages at three-phase to ground fault.

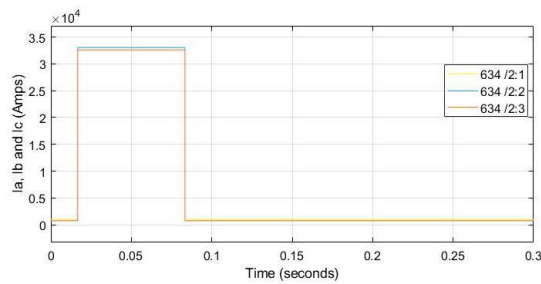

Fig. 11: Bus 634 three-phase currents at three-phase to ground fault.

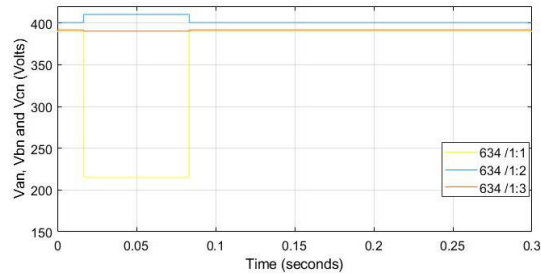
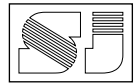

Fig. 12: Bus 634 three-phase to neutral voltages at phase A to ground short circuit.

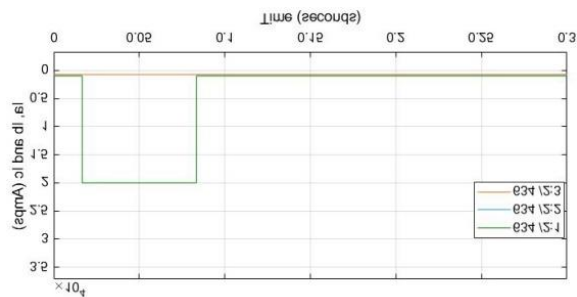

Fig. 13: Bus 634 three-phase currents at phase A to ground short circuit.

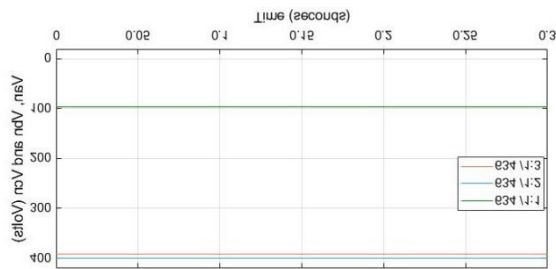

Fig. 14: Bus 634 three-phase to ground voltages at phase A open circuit.

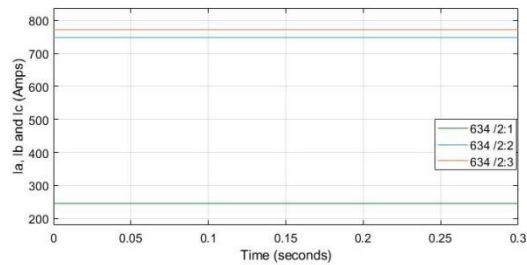

Fig. 15: Bus 634 three-phase currents at phase A open circuit.